

## v100NX Ka

**ALL NEW KA-KU DUAL BAND**  
GEO/MEO/LEO 1m Maritime VSAT Terminal



### FEATURES

#### FREQUENCY FLEXIBILITY

The v100NX Ka can be easily inter-converted from Ka- to Ku and Ku- to Ka-band operation by changing the center mounted RF Assembly and Feed using an available conversion kit.

#### GEO/MEO/LEO TRACKING CAPABILITY

The v100NX Ka is ready for the future. It is designed with the world's most accurate satellite tracking performance with our proven tracking algorithm that covers GEO, MEO, and LEO constellations.

#### EMBEDDED DUAL ANTENNA MEDIATOR

Intellian's new ACU fully supports dual antenna operation without additional complexity and components such as a separate mediator and RF splitters. Streamlined configuration of the dual antenna operation is done via AptusNX.

#### SINGLE COAXIAL CABLE

The v100NX Ka combines Tx, Rx, and DC power in a single cable solution, enabling faster installation and reduced costs. Dynamic Motor Brakes eliminate the requirement of shipping brackets, and the Dome-On external RF cable connection on the base allows faster and easier installation without removing the radome.

#### STANDARDIZED MODULAR COMPONENTS ACROSS NX SERIES

Modular components are used throughout the NX range, such as dynamically braked motors with integrated encoders, and a Main Control Unit. The sharing of common modules across Intellian's NX antenna series reduces the number of spare parts by more than 30%.

#### NEW APTUSNX

AptusNX, Intellian's all new integrated M&C platform, provides a responsive user interface to manage antenna systems. It also has an intelligent diagnosis function for accurate and enhanced antenna monitoring, and provides detailed reports and measurement for convenient maintenance.

# v100NX Ka All New Ka-Ku Dual Band GEO/MEO/LEO 1m Maritime VSAT Terminal

## TECHNICAL SPECIFICATIONS

### ABOVE DECK UNIT

Radome Height	145.4 cm / 57.4"
Radome Diameter	137.9 cm / 54.3"
Reflector Diameter	105 cm / 41.3"
Weight	113 kg / 249.1 lbs
Azimuth Range	Unlimited
Elevation Range	-20° to 115°
Cross-level Range	± 37°
Stabilization Accuracy	0.2° peak miss-pointing @ max ship motion condition
Motor Brake System	Dynamic Brake System
Tx Frequency	29.0 ~30.0 GHz Ka-band
Tx Gain	48.2 dBi @ 29.5GHz (excl. radome)
Rx Frequency	19.2 ~ 20.2 GHz Ka-Band
Rx Gain	44.5 dBi @ 19.7Ghz (excl. radome)
G/T	> 20.1 dB/K @ 19.7 GHz (Clear Sky, 30° Elevation)
BUC Power	5W and 10W
Polarization	Circular (RX: LHCP, TX: RHCP)
Antenna Cable	Single 50-ohm Coax Cable for Rx, Tx, FSK, Reference and Power from ACU to ADU

### ANTENNA CONTROL UNIT

Dimensions (WxDxH)	43.1cm x 41.1cm x 4.4cm / 17" X 16.1" X 1.7"
Weight	5.2 kg / 11.5 lbs
Display	OLED Display
Gyrocompass Interface	NMEA2000, NMEA0183
Mediator Interface	Yes
Modem Interface	Ethernet port / RS-232C,-422C / I/O Console
Modem Protocol	iDirect, Comtech, SatLink, Hughes, GILAT, Newtec
Wi-Fi Operation	Yes (w/ Wi-Fi dongle)
Management Port	Yes
Intellian LAN Port	Yes
Power Requirement	100 ~240 VAC, 50~60Hz, 4A

## SYSTEM DIMENSION

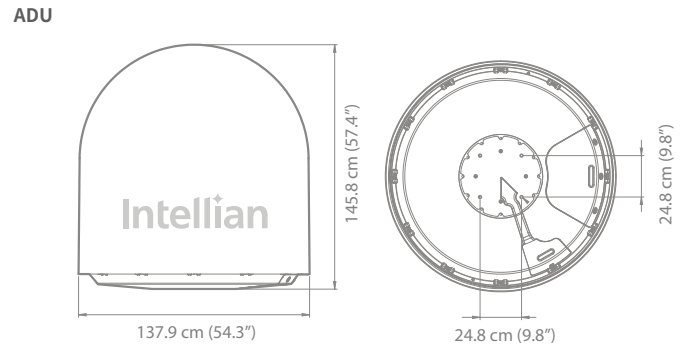

## SYSTEM DIAGRAM



## SYSTEM DIAGRAM (DUAL ANTENNA)

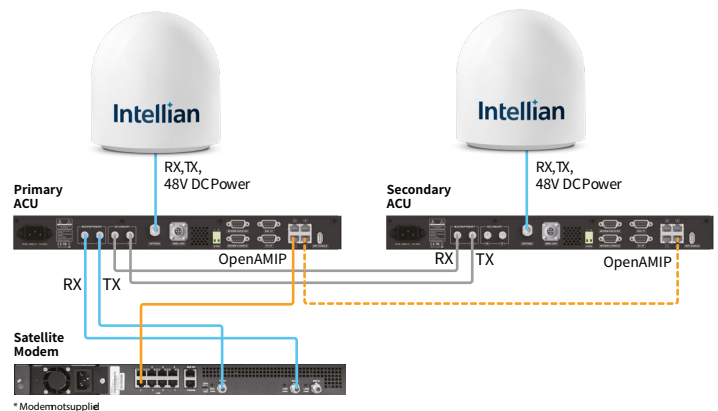

### Global HQ

Innovation Center  
Intellian Technologies, Inc  
T +82 31 379 1000 F +82 31 377 6185

### APAC

Seoul  
Intellian Technologies, Inc.  
T +82 2 511 2244 F +82 2 511 2235

### Americas

Irvine  
Intellian Technologies USA, Inc.  
T +1 949 727 4498 F +1 949 271 4183  
Toll Free +1 888-201-9223

### EMEA

Rotterdam  
Intellian B.V.  
T +31 1 0820 8655 F +31 1 0820 8656